

## CUT series

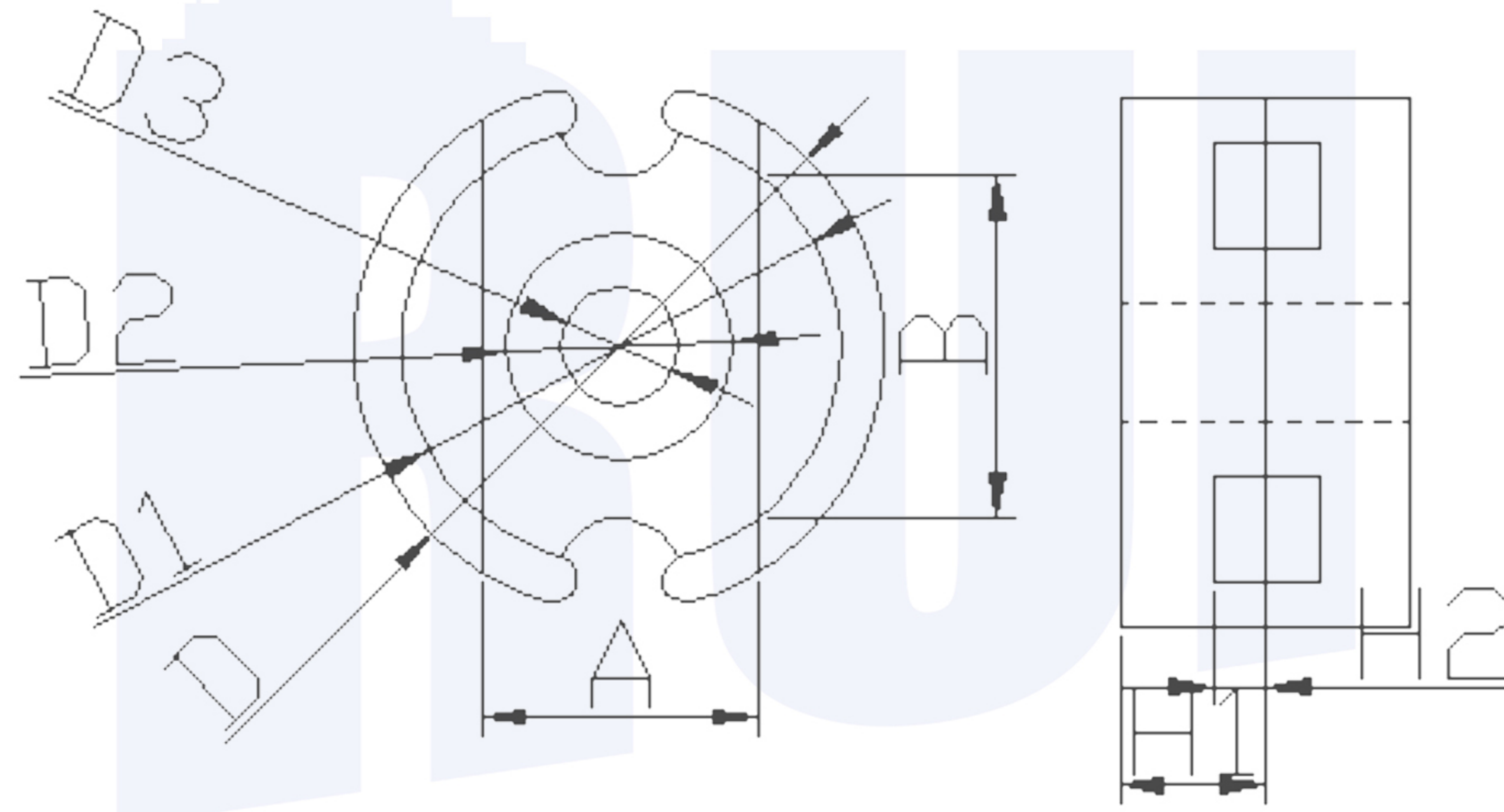

MATERIALS:SR-10P, SR-7P, SR-5P, SR-P4

TYPE	Dimension:mm								Weight:g
	A	B	H1	H2	D	D1	D2	D3	
C14×8	9.55±0.15	7.6min	4.18±0.08	2.7min	14.0±0.25	11.6min	5.99max	3.1±0.07	2.8
C18×11	12.2-0.65	9.8	5.8-0.3	3.6+0.4	18.8-0.3	15.1+0.8	7.6-0.5	2.9+0.3	6.4
C22×13	15.2±0.25	10.5	7.0-0.3	4.6+0.4	22.4-0.12	18.1+1.0	9.4-0.5	4.3+0.4	12.0
C30×19	20.3±0.3	12.5	9.4±0.1	6.6±0.1	20.0±0.5	25.4±0.4	13.3±0.2	5.55±0.15	29.0

TYPE	Effective parameter				AL (nH/N <sup>2</sup> ) (AL±25%)			
	C <sub>1</sub> (mm <sup>-1</sup> )	A <sub>e</sub> (mm <sup>2</sup> )	L <sub>e</sub> (mm)	V <sub>e</sub> (mm <sup>3</sup> )	SR-P4	SR-5P	SR-7P	SR-10P
C14×8	0.91	23.2	21.2	492	2500			
C18×11	0.67	40.6	27.2	1110	4800			
C22×13	0.47	61.0	28.6	1740	4500			
C30×19	0.347	128.1	44.4	5688	6000			